

V7

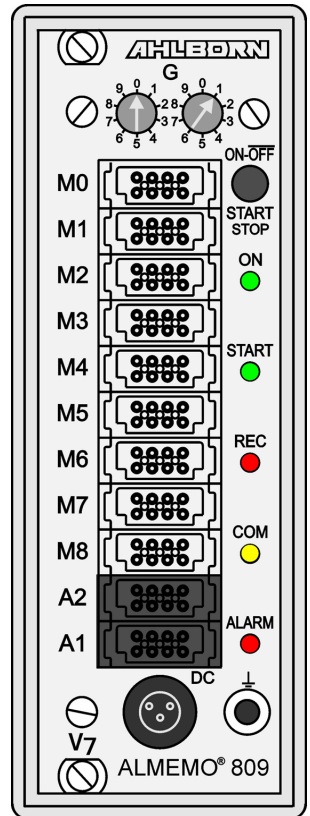

Measured data acquisition module ALMEMO[®] 809

V1.3
27.01.2022

1. OPERATING CONTROLS

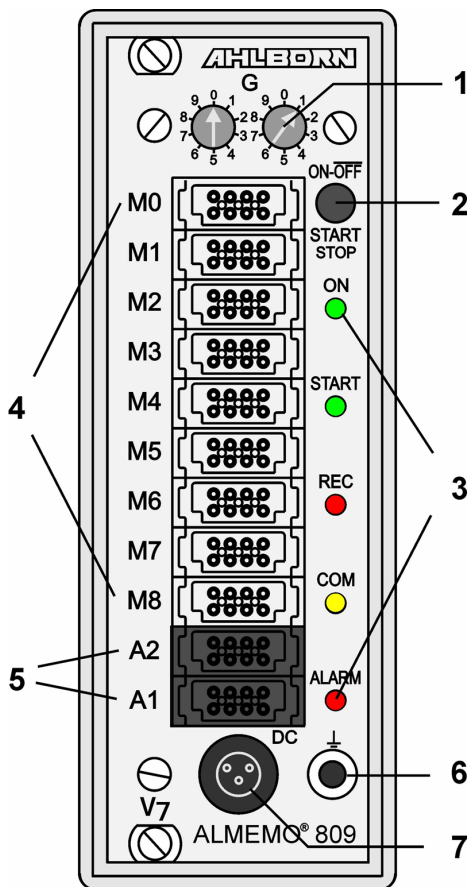

(1) Code switches

G: Device address 00 to 99

(2) Key ON / OFF, START / STOP

ON ON
START Start the meas. operation
STOP Stop the meas. operation
OFF OFF, hold key pressed down

(3) Status LEDs

ON Device is switched ON
START Meas. op. has started
REC Meas. with results saved
COM Measuring with output
ALARM Limit value infringement
 Sensor breakage, battery low

(4) Measuring sockets M0 to M8

M0...M8 for V5/V6/D6/D7 sensors
M0.1...M8.9 max. 81 channels

(5) Output sockets A1, A2

A1 USB interface (ZA1919-DKU)
 RS232/optic fiber (ZA1909-DK5/DKL)
 RS 422 (ZA 5099-NVL/NVB)
 Ethernet (ZA 1945-DK)
 Radio (ZA 1719-BPVU)
 Trigger input (ZA 1000-ET/EK)
 Relay outputs (ZA 1000-EGK)
 Analog output 1 (ZA 1601-RK)
A2 Network cable (ZA1999-NK5/NKL)
 SD card connector (ZA1904-SD)
 Trigger input (ZA 1000-ET/EK)
 Relay outputs (ZA 1000-EGK)
 Analog output 2 (ZA 1601-RK)

(6) Ground socket

(7) DC supply socket 12V

Mains adapter (ZB 1212-NAX, 12V, min.1A)
 Cable electrically isolated
 (ZB 3090-UK, 10-30V)

2. TABLE OF CONTENTS

1. Operating controls	2
2. Table of Contents.....	3
3. General.....	5
3.1 Warranty.....	5
3.2 Standard delivery.....	6
3.3 Waste disposal.....	6
4. Safety instructions	7
4.1 Special notes on use	8
5. Introduction	9
5.1 Functions of the ALMEMO® 809	10
5.1.1 Sensor programming	10
5.1.2 Measuring operation	11
5.1.3 Process control	12
6. Putting into service	15
7. Power supply	16
7.1 Mains operation	16
7.2 External DC voltage supply	16
7.3 Sensor supply	16
7.4 Switching ON / OFF, reinitialization	16
7.5 Data buffering	16
8. Connecting sensors / transducers.....	18
8.1 Standard sensors (V5,V6)	18
8.2 D6 sensors.....	18
8.3 D7 sensors.....	19
8.4 Measuring inputs , additional channels	19
8.5 Potential separation	20
9. Operation and configuration	21
9.1 Combination key	21
9.2 Status LEDs	21
9.3 Device address and networking.....	21
9.4 Configuration, new V7 functions	22

2. Table of Contents

10.	Measured data acquisition	24
10.1	Online measurement with PC	24
10.2	Offline measurement.....	24
10.2.1	Sleep mode.....	25
10.2.2	Measured value memory, internal.....	25
10.2.3	Memory connector with SD memory card.....	26
11.	Special measured quantities, Linearization, Multi-point calibration	27
12.	Trouble-shooting	27
13.	Declaration of conformity	29
14.	Annex.....	30
14.1	Technical data	30
14.2	Product overview	30
14.3	Index	31
	Your contact	32

3. GENERAL

Congratulations on your purchase of this latest V7-generation ALMEMO® measured data acquisition module. Thanks to the patented ALMEMO® connector and the new digital D7 sensors the device configures itself automatically and thanks to the supplied ALMEMO® Control software its operation should be fairly straightforward. The device can, however, be used with a wide range of sensors and peripherals and offers many different special functions. You are advised to take the time to carefully read these operating instructions and the relevant sections in the ALMEMO® Manual and to properly familiarize yourself with the way these new sensors function and with the range of features the V7 device now provides. This is the best way to avoid operating and measuring errors and prevent damage to the device. To help you find answers to your questions as quickly and easily as possible a comprehensive index is provided at the end of these instructions and at the end of the Manual.

3.1 Warranty

Each and every device, before leaving our factory, undergoes numerous quality tests. We provide a guarantee, lasting two years from delivery date, that your device will function trouble-free. Before returning your device to us, please observe the advisory notes in Chapter 12, 'Trouble shooting'. In the unlikely event that a device does prove defective and you need to return it, please wherever possible use the original packaging materials for dispatch and enclose a clear and informative description of the fault and of the conditions in which it occurs.

This guarantee will not apply in the following circumstances:

- Any form of unauthorized tampering or alteration inside the device
- Use of the device in environments or conditions for which it is not suited
- Use of the device with an unsuitable power supply and / or in conjunction with unsuitable peripheral equipment
- Use of the device for any purpose other than that for which it is intended
- Damage caused by electrostatic discharge or lightning
- Failure to properly observe these operating instructions

The manufacturer reserves the right to change the product's characteristics in the light of technical progress or to benefit from the introduction of new components.

3. General

3.2 *Standard delivery*

When you unpack the device please check carefully for any signs of transport damage and ensure that delivery is complete.

Measuring instrument ALMEMO® 809

Mains adapter

These operating instructions

In the event of transport damage please retain the packaging material and inform your supplier immediately.

3.3 *Waste disposal*



The pictogram showing a waste bin crossed through means that the product is subject to European Union regulations covering segregated waste disposal. This applies both to the product itself and to any accessories marked with the same symbol. Disposal of any such item as unsorted domestic waste is strictly forbidden

- Please dispose of all packaging materials in accordance with the applicable national waste management regulations.
- Please dispose of cardboard boxes, protective plastic packaging materials, and all preservative substances separately and in the proper manner.
- The disposal of the device itself (also of device parts, accessories, and consumables) is subject to the applicable national and local waste management regulations and to the environmental protection legislation in force in the country of use.
- Please dispose of all waste in the proper manner; this applies in particular to all parts and substances that constitute a hazard for the environment. This includes inter alia plastics, batteries, and rechargeable battery packs.
- For the dispatch of such goods please wherever possible use the original packaging materials.

4. SAFETY INSTRUCTIONS

DANGER Danger to life and limb, risk of damage to equipment



Before starting to operate the device, please read the instructions carefully.

Please ensure that you comply with all general safety advice and the special safety instructions included in other chapters.

Such risks may occur in the following circumstances:

Failure to heed the operating instructions and all the safety notes these contain

Any form of unauthorized tampering or alteration inside the device
Use of the device in environments or conditions for which it is not suited

Use of the device with an unsuitable power supply and / or in conjunction with unsuitable peripheral equipment

Use of the device for any purpose other than that for which it is intended

Damage caused by electrostatic discharge or lightning.

DANGER Risk of fatal injury through exposure to dangerously high voltage



Such risks may occur in the following circumstances:

Use of the device with an unsuitable power supply and / or in conjunction with unsuitable peripheral equipment

Damage caused by electrostatic discharge or lightning

Do not run sensor lines in the vicinity of high-voltage power cables.

Before you touch any sensor lines, ensure that all static electricity has been discharged.

DANGER Warning - explosive atmospheres or substances



In the vicinity of various fuels or chemicals there is a risk of explosion.



Do not use the device in the vicinity of blasting work or filling stations.

4. Safety instructions

4.1 *Special notes on use*

- If the device is brought into the work-room from a cold environment there is a risk that condensation might form on the electronics. In measuring operations involving thermocouples pronounced changes in temperature may cause substantial measuring errors. You are advised therefore, before starting to use the device, to wait until it has adjusted to the ambient temperature.
- Before using the mains adapter make sure that the mains voltage is suitable.
- Be sure to observe the maximum load capacity of the sensor power supply.
- Sensors with their own integrated power supply are not electrically isolated from one another.
- Do not run sensor lines in the vicinity of high-voltage power cables.
- Before you touch any sensor lines, ensure that all static electricity has been discharged.

5. INTRODUCTION

The V7 measured data acquisition module ALMEMO® 809 is a brand new member in our family of unique measuring instruments - all equipped with Ahlborn's patented ALMEMO® plug system. The ALMEMO® plug offers - and has offered for the last 20 years - decisive advantages when connecting sensors and peripherals because all parameters are stored in an EEPROM located on the connector itself; repeated programming is thus no longer necessary. Any sensor or output module can be connected to any ALMEMO® measuring instrument - all in the same way.

However, the new generation of intelligent digital ALMEMO® D7 sensors, operating in conjunction with our V7 measuring instruments, overcomes all limitations to which the system was previously subject. Each such sensor, irrespective of the device's measuring quantities and ranges, can operate as an autonomous measuring system with up to 10 channels and provide completely new measurable variables with all necessary control functions, calculating functions, or compensation values, with a range of values up to 8 digits and at speeds up to 1 kHz. What is so special about this new generation is that, thanks to the individual sampling rates used, high-resolution variables, both quick and slow, can now very easily be measured and recorded together. Individual functions can be parametrized via a menu stored in the plug itself. To facilitate identification the quantity abbreviations and units have been extended to 6 digits and the measuring point comments to 20 characters. All sensors belonging to the preceding V6 generations can be used on V7 devices but the new D7 sensors are not backwardly compatible with V6 devices. However, they can be operated directly on the PC via the serial interface and an adapter cable. What is completely new with the V7 generation is the channel numbering system. Sensors and sockets are counted from 0 to 9; this is followed by the channels counted as decimals also from 0 to 9; i.e. the first sensor has channels 0.0 to 0.9, the second has 1.0 to 1.9, etc.

Programming and functioning are virtually identical for all units.

The following points apply to all devices in the ALMEMO® measuring system; these are described in detail in the ALMEMO® Manual which is included in delivery with each device.

Detailed explanation of the ALMEMO® system (Manual, Chapter 1)

Overview of the device functions and measuring quantities and ranges (Manual, Chapter 2)

Basic principles, operating instructions, and technical data for all sensors (Manual, Chapter 3)

Options for connecting your own existing sensors (Manual, Chapter 4)

All analog and digital output modules (Manual, Section 5.1)

Interface modules RS232, optic fiber, USB, Ethernet (Manual, Section 5.2)

The whole ALMEMO® networking system (Manual, Section 5.3)

All functions and their operation via the interface (Manual, Chapter 6)

Complete list of interface commands with all the printouts (Manual, Chapter 7)

5. Introduction

The operating instructions you are now reading cover only those features and controls that are specific to this device. Many sections refer to more detailed descriptions in the Manual. (Manual. Section x.x.x).

5.1 Functions of the ALMEMO® 809

Measured data acquisition module ALMEMO® 809 is housed in a compact 8-DU case; it has 9 electrically isolated measuring inputs suitable for all ALMEMO® sensors. Given the large portfolio of V6 sensors and now the new, innovative D7 sensors measuring possibilities are nowadays virtually limitless. Thanks to the external memory connector with a micro SD card and the real-time clock, all incorporated as standard on the ALMEMO® 809, the amount of data you can record is virtually endless. The ALMEMO® 809 also incorporates a high-speed 8-MB flash memory sufficient for up to 1.5 million measured values. There are two output sockets which can be used to connect any of the ALMEMO® output modules, e.g. analog output, digital interface, memory connector, trigger input, or alarm contacts. Multiple V7 devices can be networked together by simply connecting them via network cable.

5.1.1 Sensor programming

The measuring channels are programmed, completely and automatically, via the ALMEMO® plugs. However, the user can easily supplement or modify this programming via the interface.

Measuring quantities and ranges

Appropriate measuring quantities and ranges are available for all V6 sensors with a non-linear characteristic, e.g. 10 thermocouple types, NTC and Pt100 probes, and flow transducers (rotating vanes, hot-wire thermoanemometers, Pitot tubes). For humidity sensors there are additional function channels available for calculating humidity variables such as dewpoint, mixture ratio, absolute humidity, vapor pressure, and enthalpy - now on the basis of the latest formulae as per Dr. Sonntag. Even complex chemical sensors are supported. Measured values from other sensors can also be acquired using the voltage, current, and resistance quantities with individual scaling in the plug itself. Existing sensors can still be used - so long as the appropriate ALMEMO® plug is connected via its screw terminals. For digital input signals, frequencies, and pulses there are adapter plugs available with an integrated microcontroller. The new autonomous D7 sensors already provide this wide range of features but also in the future they herald as yet unimagined possibilities in data acquisition from both digital and analog sensors and in all manner of data formats. It will even be possible to control the measuring system itself. It is for example possible to connect an increasing range of sensors to the ALMEMO® V7 measuring instrument and to change sensors without needing to reset.

Function channels

Maximum, minimum, average, and differential values of certain measuring

points can be programmed as function channels and can be processed like normal measuring points. There are also function channels available for special measuring tasks, e.g. to determine thermal coefficient $Q/\Delta T$ and the wet-bulb globe temperature.

Units

The units display (V6 two characters, D7 up to six characters) can be adapted for each measuring channel in such a way that both the display and via interace always indicate the correct units, e.g. when a transmitter is connected. Conversion between °C (Centigrade) and °F (Fahrenheit) is performed automatically.

Measured value designation

To help identify sensors an alphanumeric designation is also provided (V6 10 characters, D7 up to 20 characters). This name is entered via the interface and will appear via interface and in the software.

Correction of measured values

The measured value on each measuring channel can be corrected both in terms of zero-point and gain; this means that even sensors usually requiring initial adjustment (e.g. expansion, force, pH) can be interchanged freely. Zero-point correction and, partly at least, gain adjustment can be performed at the touch of a button.

There is also the possibility of performing multi-point adjustment or user-defined linearization.

Scaling

The corrected measured value on each measuring channel can also be further scaled in terms of zero-point and gain based on the base value and factor. The decimal point position can be set by means of the 'Exponent' function. Scaling values can be calculated automatically by setting to zero and entering the nominal setpoint.

Limit values and alarm

Per measuring channel two limit values can be set (one maximum and one minimum). In the event of one of these limit values being infringed relay output modules actuate the associated alarm contacts; these can be allocated individually to specific limit values. Hysteresis is set by default to 10 digits; however, this can be adjusted to any value between 0 and 99 digits. A limit value infringement can also be used to automatically start or stop measured value recording or via macros to control device functions in any way required.

Sensor locking

All sensor data stored in the EEPROM in the plug can be protected - by means of a graduated locking function - against undesired access.

5.1.2 Measuring operation

For nine V6 sensors up to 36 measuring channels are available; i.e. it is thus also possible to evaluate double sensors, individually scaled sensors, and sen-

5. Introduction

sors with function channels. All activated V6 measuring channels are continuously scanned at a rate of 10 MOPS (measuring operations per second). When there are numerous measuring points to consider, the overall response time can be shortened by increasing the measuring rate up to 100 MOPS. A D7 sensor has up to 10 channels and a sampling rate corresponding to its own individual measuring speed.

Measured values

Measured values are acquired automatically with auto-zero and self-calibration; however, they can also be corrected and scaled individually as required. With most sensors a sensor breakage is detected automatically.

Analog output and scaling

Each measuring point can be scaled by means of analog start and analog end in such a way that the measuring range thus defined covers the full range of the analog output (2 V, 10 V, or 20 mA). At the analog output the device can output the measured value from any measuring point or a programmed value.

Measuring functions

To achieve optimal measured value acquisition some sensors require certain special measuring functions. Cold junction compensation is provided for thermocouples; temperature compensation is provided for dynamic pressure, pH, and conductivity probes; and atmospheric pressure compensation is provided for humidity, dynamic pressure, and O₂ sensors.

Measured value smoothing

With V6 sensors measured values of an unstable, fluctuating nature can be smoothed by taking a sliding average over a number of values programmable between 2 and 99. The averaging period will depend on the sampling rate and the number of active channels. However, D7 sensors are assigned their own fixed averaging period for all primary channels; this can be set via the sensor menu.

Maximum and minimum values

Each measuring operation acquires and stores the maximum and minimum values with date and time-of-day. Each of these values can be output, used as function channel, or deleted.

Average value

Manual averaging is available per channel over a particular period or cycle or over a series of individual measuring operations.

5.1.3 Process control

To record the measured values from all connected sensors in digital form measuring point scanning must be performed continuously with measured value output according to a process scheduling system. This may be per output cycle or, if rapid results are required, at the measuring rate itself. Data from each D7 sensor is acquired individually per scan cycle; this can be adjusted to suit the

fastest acting sensors, slower acting ones being omitted until new updated values appear.

A measuring operation can be started and stopped by means of a key, the interface, an external trigger signal, the real-time clock, or by a specified limit value infringement.

Date and time-of-day

Each measuring operation can be accurately logged using the real-time clock in terms either of date and time-of-day or purely by actual measuring duration. For the purposes of starting / stopping a measuring operation the start / stop date and time-of-day and / or the actual measuring duration can be programmed.

Cycle

The output cycle can be programmed to any value between 1 second and 24 hours. This function permits cyclic output of measured values to the interfaces or to the memory and provides cyclic calculation of the average value.

Cycle factor

The cycle factor can be used to restrict data being output from certain channels at the output cycle; this may prove necessary in order to reduce excessive data flow while measured data is being saved. With D7 sensors the individual scan time already set can be changed to a longer preferred scan time.

Averaging over measuring point scans

The measured values from measuring point scans can be averaged either over the whole fixed measuring period or over the specified cycle. These average values can then be output and saved on a cyclic basis to function channels provided for this purpose.

Conversion rate

The conversion rates available for V5 / V6 sensors are 2.5 / 10 / 50 / 100 MOPS (measuring operations per second). Recording can be accelerated if all measured values are stored to memory and / or output via the interface at the conversion rate. Among D7 sensors there are especially fast models with a scan time of just 1 millisecond, which permits a sampling rate of 1000 MOPS.

Measured value memory

To save measured values there are two alternative methods. The ALMEMO® 809 incorporates a non-volatile 8-MB flash memory sufficient for up to 1.5 million measured values. This memory can be organized and configured in either linear or ring form. Output is via the interface. Selection can be specified according to date or number.

Or alternatively an external memory connector fitted with a memory card can simply be connected at socket A2. This solution, depending on the size of the card, offers a virtually limitless memory capacity. With an external memory connector, available as an accessory, files can be read out very quickly via any standard card reader.

Numbering of measuring operations

By entering a number single scans or entire series of measuring operations can

5. Introduction

be identified and selectively read out from memory.

Control outputs

Via the keypad and interface up to ten output relays and up to four analog outputs can be individually addressed.

Output

All data logs, all saved measured values, and all programming parameters can be output to any peripheral equipment. RS232, RS422, USB, and Ethernet interfaces are available via the appropriate interface cables. Wireless communication is also possible via radio. To accommodate the variable data quantities provided by D7 sensors the interface protocol has been changed so that data is now output in table format only; this can then if so required be processed directly using any standard spreadsheet program.

Networking

All ALMEMO® devices can be individually addressed and can be networked together by simply linking them up via network cable. However, old V5 / V6 devices and the new V7 devices use different protocols and must therefore be operated via different COM ports.

Software

Each ALMEMO® Manual is accompanied by the ALMEMO® Control software package, which can be used to configure the measuring instrument, to program the V6 and D7 sensors, and to read out from the measured value memory. Using the integrated terminal, measuring operations can also be performed online. The WINDOWS® software package WinControl is provided for measured value acquisition from networked devices, for graphical presentation, and for more complex data processing.

6. PUTTING INTO SERVICE

1. **Sensor connection** Connect sensors to sockets **M0** to **M8** (4). see Section 8.
 2. **Power supply** Connect mains adapter to socket DC (7). see Section 7.1
 3. **Switching ON** Press the **ON** key (2). see Section 7.4
 4. **Register device on the PC**
Connect the computer via interface cable to socket A1. see Man. 5.2
Activate the software, e.g. the supplied ALMEMO® Control. Via <Interface> set the COM port and transmission rate to 9600 baud. see Man. 6.1.1
Register device via <Find connected devices>.
 5. **Check sensors and, if necessary, program.**
In main menu <Measuring points> select and check <List>.
If so required select channel and <Program measuring point>.
 6. **Program the device** in device list via <Program device>
For automatic measuring point scan enter 'cycle'. see Man. 6.5.2
For quick measuring operation use sampling rate or scan cycle (D7). see 9.4
To save activate 'With memory'.
If so required 'Accept date and time-of-day from PC'. see Man. 6.2.8
 7. **Measured data acquisition from PC without saving in device**
In main menu activate <File - terminal>. see Man. 6.1.3
Select <File> - <Terminal> - <Open log> and then enter file name, 'Save'.
Start measuring operation by actuating the 'Start' button or pressing the **START/ STOP** key. see Man. 6.6
Stop measuring operation by actuating the 'Stop' button or pressing the **START/ STOP** key. Select <File> - <Terminal> - <Close log>. Call up file e.g. from MS-Excel and import using ';' as separator. see Man. 6.1.4
 8. **Saving measured values in the device**
In main menu <Devices> activate <Measured value memory>.
If so required click on 'Clear memory' and 'Execute'. see Man. 6.9.3
For long-term recording set scan mode 'Sleep' (cycle > 2 minutes). see 10.2.1
Activate 'Start saving to memory' immediately
 or Start measuring operation on site by pressing **START/ STOP** key
 or Enter 'Start date', 'Start time', and 'End date', 'End time'. see Man. 6.6.2
At the end of the measuring operation stop recording by pressing the **START/ STOP** key.
- Transferring data from memory to the computer**
If the memory connector is being used withdraw the memory card and using a USB reading device copy to the PC see Man. 6.9.4.2 or Reconnect the computer via interface cable to socket A1. see above In ALMEMO® Control call up <Devices - Measured value memory>. Click on 'Read out whole memory'.
Read out, 'Execute', enter file name, 'Save'. see Man. 6.9.3
Call up file e.g. from MS-Excel and import using ';' as separator. see Man. 6.1.4.

7. POWER SUPPLY

Power can be supplied to the measuring instrument in any of the following ways

: Mains adapter 12 V / min. 1 A	ZB 1212-NAx
Power supply cable, electr. Isol. (10 to 30 VDC, 0.25 A)	ZB 3090-UK
Power supply cable, electr. Isol. (10 to 30 VDC, 1.25 A)	ZB 3090-UK2

See product overview, Annex 14 and the following chapters.

7.1 Mains operation

To power these devices from the mains preferably use the mains adapter provided (for type see above); connect it to the socket DC (7).

7.2 External DC voltage supply

The DC socket (7) can also be used to connect another DC voltage, 9 to 13 V (minimum 200 mA). For this connection use a cable with 2 banana plugs (ZB 5090-EK). If, however, the power supply has to be electrically isolated from the transducers or if a larger input voltage range (10 to 30 V) is required, then an electrically isolated supply cable must be used (ZB 3090-UK). It will then be possible to use the measuring instrument in a 12-volt or 24-volt on-board supply system.

7.3 Sensor supply

An den Klemmen – und + im ALMEMO®-Stecker steht bei Netzbetrieb eine Fühlerversorgungsspannung von 12V (400mA) zur Verfügung (selbstheilende Sicherung 500 mA). Andere Spannungen (12V, 15V, 24V oder Referenzen für Potentiometer und Dehnungsmessstreifen) sind mit speziellen Steckern erreichbar (s. Hb. 4.2.5/6).

7.4 Switching ON / OFF, reinitialization

To switch the device ON / OFF press the ON / OFF key (2).

To switch the device OFF press the ON / OFF key and hold down for approx. 1 second. After the device is switched off the real-time clock continues to run and all saved values and settings are retained intact.

If interference (e.g. electrostatic or mains failure) causes the device to behave abnormally, you are advised first of all to try clearing the problem by simply reinitializing, i.e. switching off and then on again.

If this does not help then you are advised to restore all device programming to the factory default settings. The device can be reset by setting the code switch G (1), before switching on, to address 99. The device name, device programming with all settings, memory and macros are deleted and the baud rate setting in the data cable is reset to 9600 baud. Only the time, device calibration and programming of the sensors in the ALMEMO® connectors remain unaffected.

7.5 Data buffering

The sensor's programming is stored in the EEPROM on the sensor plug; the

device's calibration and programmed parameters are stored in the EEPROM on the device itself; both are fail-safe. The memory data is also saved in non-volatile EEPROMs. Date and time-of-day are buffered by a dedicated lithium battery; this data is retained intact for years - even when the device is switched off and without batteries.

8. CONNECTING SENSORS / TRANSDUCERS

Virtually any ALMEMO® sensor can be connected to any of the input sockets M0 to M8 on the ALMEMO® measuring instrument (1); (this includes all standard V5 and V6 sensors and newer D6 and D7 digital sensors). The ALMEMO® Manual includes detailed descriptions of the comprehensive ALMEMO® range of sensors (see Manual Ch. 3) and instructions for connecting your own existing sensors to ALMEMO® instruments (see Manual Ch. 4). To connect your own existing sensors you simply need the appropriate ALMEMO® plug. All standard sensors with an ALMEMO® plug usually have the measuring quantity, range, and units already programmed and can thus be connected to any input socket without further adjustment. A mechanical coding system ensures that sensors and output modules can only be connected to the correct sockets. All ALMEMO® plugs incorporate two snap-lock levers; these snap into position as soon as the plug is inserted into the socket, thus preventing unintended disconnection if the cable is pulled accidentally. To withdraw the plug these two levers must first be pressed in at the sides.

8.1 Standard sensors (V5, V6)

Standard ALMEMO® V6 sensors are housed in a light-gray case. The exclusive source of their intelligence is a 4-KB EEPROM (E4) integrated in the sensor plug, in which all channel settings are stored; the device is thus programmed completely as soon as any such sensor is connected. These sensors also support multi-point calibration. Older sensors (V5) with an EEPROM of only 2 KB do not yet support this feature. Passive analog sensors are electrically isolated from one another by means of photovoltaic relays; all signals in the device are converted analog-to-digital.

Digital sensors used for the quantities - frequency, pulse, or DIGI - incorporate a microcontroller, which transfers digital signals to the device via an I²C bus.

Measured values are processed in synchrony with the conversion rate (maximum 100 MOPS) and at a resolution of maximum ± 65000 all in the device including linearization and various forms of compensation.

8.2 D6 sensors

ALMEMO® D6 sensors are housed in a partly light-gray, partly dark-gray case; they are completely autonomous measuring modules not only for digital but also for analog sensors; they can, independently of the device, handle new measuring quantities and ranges with special measured value processing and various forms of compensation. As regards measured value processing D6 sensors are fully compatible with standard sensors - except for multi-point calibration and smoothing; however, quantity and range configuration and parametrization must be performed via the special 'Sensor configuration' menu in the ALMEMO® Control software either on the V7 device itself or, using a USB adapter cable, directly on the PC.

(see additional instructions 'Digital ALMEMO® D6 sensors').

8.3 D7 sensors

ALMEMO® D7 sensors are housed in a dark-red case; they too are completely autonomous measuring modules for digital and for analog sensors - but offer substantially enhanced properties. The conversion rate can be set from 1 milli-second up to several minutes with a resolution up to 8 digits. The number of channels has, thanks to a new numbering scheme, been extended up to 10 per sensor and up to 10000 per device. Channel designations can be up to 20 characters and units up to six characters in length. With D7 sensors up to four primary channels can also be smoothed at the same time internally over the averaging period. For the purpose of setting individual parameters (e.g. quantities and ranges, averaging period) special menu 'Sensor configuration' is provided by the sensor itself. (see additional instructions 'Digital ALMEMO® D7 sensors') All measured value processing is performed in the sensor itself; the resulting data is transferred no longer via an I2C bus but via the serial interface alone. For this reason and because of the expanded data format D7 sensors can only be operated in conjunction with a V7 device or directly on a PC. For D7 sensors dedicated extension cables and an adapter cable for electrical isolation are available.

8.4 Measuring inputs , additional channels

Measuring instrument ALMEMO® 809 incorporates nine input sockets M0 to M8 (1); to these, under the new channel numbering scheme, measuring channels M0.0 to M8.0 are initially assigned. Whereas standard sensors can if necessary provide up to four channels (M0.0 to M0.3, M1.0 to M1.3, etc.), D7 sensors can provide up to 10 (M0.0 to M0.9, M1.0 to M1.9, etc.). The additional channels can be used in particular for humidity sensors with numerous measurable variables (temperature / humidity / dewpoint / mixture ratio) or for function channels. Each sensor can if necessary be programmed with several quantities or scaling settings; and two or three sensors, if pin assignment so allows, can be combined in a single plug (e.g. RH / NTC, mV / V, mA / V, etc.).

This device does not incorporate any internal channels.

On the measuring instrument this gives the following channel assignment:

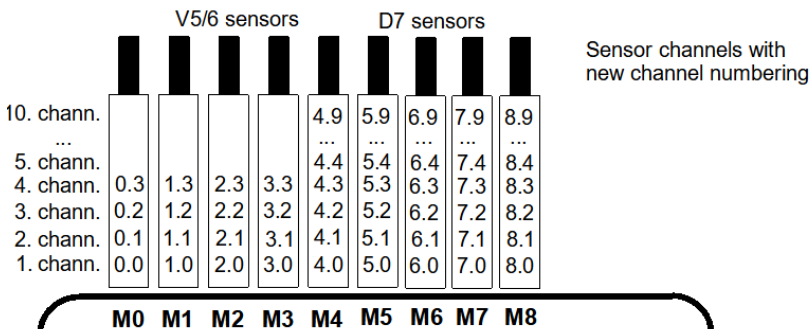

8.5 Potential separation

When organizing a properly functioning measuring setup it is very important to ensure that no equalizing current can flow between sensors, power supply, and peripherals. All measuring points must therefore either be insulated (e.g. by air spacing) or lie at the same potential - and any unequal potentials that do exist must be electrically isolated.

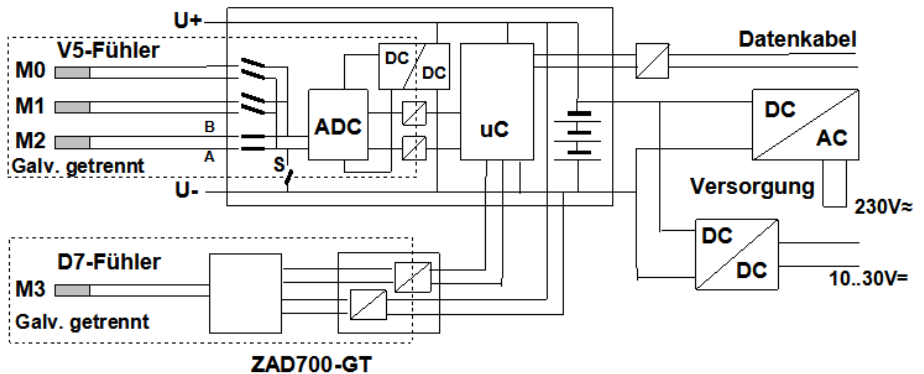

The nine analog inputs on this device are electrically isolated from one another by means of photovoltaic relays. A new feature is the additional separation of the measuring inputs from the CPU and power supply. However, for some analog sensors this electrical isolation may have to be disabled again by means of relay S (see above) or a wire jumper; some inputs would otherwise be left without reference potential. The first time any such sensor is connected this relay is set automatically by means of element flag 5 'ISO OFF'. (see Man. 6.10.3) However, with certain connectors (e.g. divider connectors without power supply) element flag 5 should be checked and if necessary corrected. Between all inputs and outputs (even those analog output cables not electrically isolated) the maximum potential difference permitted is 50 V. The voltage at the measuring inputs themselves (between B, C, D, and A) must not exceed 12 V.

However, some components are not electrically isolated, namely all sensors connected to the common internal power supply $\pm U$ and sensors combined within one connector. This also includes all D7 sensors; each such sensor (in particular electrical measuring connectors) must therefore be used with a small adapter cable ZA D700-GT; this provides electrical isolation for the power supply and data lines. Such problems do not affect sensors without a conductive connection. Non-insulated sensors can be sufficiently protected by electrically isolating the power supply (battery, mains adapter, or connecting cable with DC/DC converter).

Data and trigger cables are also insulated by means of optocouplers.

9. OPERATION AND CONFIGURATION

Measured data acquisition module ALMEMO® 809 has only a few operating controls; it is operated mainly via a PC.

9.1 Combination key

The first function of the one and only key ON/OFF - START/STOP (2) has already been described in Section 6.5.

Press to switch the device ON and press and hold down to switch OFF again. If the device is on and a cycle has been programmed the same key can be used to start and stop a measuring operation.

The current operating status is clearly shown by the status LEDs.

9.2 Status LEDs

The status LEDs (3) report the current device status as follows:

ON	Device is switched ON
ON flashes briefly just once	Device is in sleep mode
START is lit continuously	Cyclic measuring has started
COM is lit continuously	Measured values are transmitted to the PC-per output cycle
COM flashes	Measured values are transmitted to the PC - per scan cycle
REC is lit continuously	Data is being saved to device memory per cycle. This also lights up during output from memory.
REC flashes	Data is being saved to memory per scan cycle
START flashes briefly just once	Once-only measuring point scan is initiated by the PC
COM flashes briefly just once	Once-only measuring point scan transmits data to the PC
REC flashes briefly just once	Once-only meas. point scan saves data to device memory
ALARM	Limit value infringement or sensor breakage
ALARM flashes	Supply voltage to device is too low

9.3 Device address and networking

The ALMEMO® 809 data logger, like all ALMEMO® devices, can also be networked. To communicate with networked devices it is absolutely essential that each device should have its own dedicated address; this is because only one device should respond per command. Before each network operation therefore all measuring instruments must be set, by means of their code switches (1), to different device numbers.

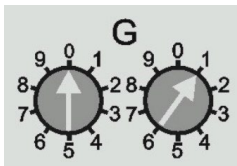

Example: Module address 01



In network operation consecutive numbers between 01 and 99 should be used; this ensures that device 00 is not addressed unnecessarily in the event of interruption to the power supply.

9.4 Configuration, new V7 functions

For the purposes of programming and configuration the supplied ALMEMO® Control software is ideally suited. This can be used to modify the sensor programming and to configure the process control. The various possibilities are explained in detail in the Manual, Section 6.8. This also describes how all functions can be programmed using ASCII commands via a terminal.

New V7 functions

This section lists all the new V7 functions not supported by V6 devices. Most such functions are only supported in conjunction with D7 sensors.

1. The new channel numbering scheme has already been described in detail in Chapter 8.4; this applies to all sensors. Channel numbers are now entered with a decimal point; the range of channel numbers available goes up to 999.9. Channels are now scanned per sensor; this improves the consistency of measured values.
2. The use of autonomous digital D7 sensors which provide measured values themselves in parallel and in full allows a much higher but also variable measuring speed. With D7 sensors the individual scan time (minimum 1 ms) can be changed to a freely selectable longer preferred scan time. The process of scanning and output of data to memory or an interface is performed in less than one millisecond per channel. To achieve this speed a new scan cycle has been introduced; this operates in the range of 1 millisecond up to 99 seconds and can only be used to monitor the maximum, minimum, and limit values or to output to interface or memory. It is controlled (as previously) by means of the sampling rate output flags 'save-to-memory continuous' and 'output continuous'.

To help the user choose the most suitable scanning rate the following table is provided.

Minimum time	Scan time for the fastest sensors
Conversion time	Time for A/D converter per V6 channel
Scan time	Time for A/D converter for all V6 channels
Maximum time	Scan time for the slowest sensors

The most suitable scanning rate generally for all sensors is 'minimum time'. What is special about this scan setting is that data from both high-speed and low-speed sensors can be acquired together without generating large quantities of superfluous junk data. Slow D7 or V6 sensors are simply omitted until a new measured value is detected.

To obtain up-to-date values the scan cycle can of course be programmed to any setting - but preferably to a multiple of the high-speed sensors.

Time-stamp resolution

will depend on the scan cycle selected.

3. The autonomous D7 sensors can now handle a measured value volume up

to 8 digits plus arithmetic sign. They can also handle text, time-of-day, and coordinates. Output to an interface or to memory is now only supported therefore in the form of an ASCII string and in table format. There is thus no longer a choice between various output formats.

4. Each D7 sensor normally has its own digital measuring quantity and range but this can be selected via the V7 measuring instrument. The quantity abbreviation has been extended to six characters. Functions for controlling the measuring sequence or for measured value compensation are performed in the sensor itself and the sensor itself, similarly, provides a menu for configuring any necessary individual parameters.
5. With D7 sensors the units and comments text have been adapted to meet rising demands; they have been extended, units to 6 and comments text to 20 characters.
6. With V6 devices the smoothing of unstable measured values by taking a sliding average could be performed on the selected measuring channel only. Most D7 sensors provide this function for up to four primary channels. This can be set, similarly, via the afore-mentioned sensor menu. (see D7 sensor instructions).

10. MEASURED DATA ACQUISITION

Measured data acquisition can be performed in basically two ways.

1. Perform measuring operation online; data is transferred to the PC immediately (no device-internal memory is required).
2. Perform measuring operation offline; data is first saved to the device's internal memory or to an external memory connector with a micro SD card and then transferred to the PC later.

10.1 *Online measurement with PC*

For conveniently recording measured data directly on the PC our WinControl measured value acquisition software is ideally suited. This software is unique in that it can scan one stand-alone or several internetworked measuring modules each at its own measuring cycle, then save the measured data on the PC, and output it online in a clearly understandable form as a line diagram, table, or list of individual measured values; thus for process control purposes you need simply program each measuring cycle in WinControl. There are numerous other possibilities using formula channels, control and regulation functions, alarm reports via SMS and e-mail, etc. but it would be going too far to describe all these here in detail.

10.2 *Offline measurement*

For offline measuring operations, i.e. data logging in the device itself, either the device's own 8-MB flash memory or an external memory connector with a micro SD card must be used.

It is an indispensable prerequisite that the following parameters be configured :

1. Date, time-of-day
2. Cycle or scan cycle with saving to memory activated
3. Sleep mode, possibly

The easiest way to do this is by means of our ALMEMO® Control software, in menu <Program device> and <Measured value memory - Save to memory>.

To start and stop a measuring operation on site there are numerous methods available. (see Man. 6.6)

1. Press the **START / STOP** key (2) on the device.
2. Program the start date and time-of-day and then either the end date and time-of-day or the fixed measuring period. (see Man. 6.6.2)
3. Reaction in the event of a limit value being overshoot or undershot (see Man.6.6.3)
4. Triggering in response to electrical signals (see Man. 6.6.4)

The status of a measuring operation and of data recording can easily be traced by watching the LEDs. (see 9.2)

To read out the measured data select ALMEMO® Control menu item <Devices -
24

Measured value memory>. (see Man. 6.9.3) Here you can transfer to a file on the PC either the complete memory or parts of it selected according to date or by number; the device memory can then be cleared.

10.2.1 Sleep mode

For long-term monitoring involving long measuring cycles where power is supplied by rechargeable or normal battery the measuring instrument can also be operated in sleep mode. In energy-saving sleep mode the measuring instrument switches off after each measuring point scan and switches on again automatically after the cycle expires ready for the next measuring point scan. In this way, with just one battery recharge, it is possible to perform up to 30,000 measuring point scans; with a cycle lasting 5 minutes this represents a total runtime of over 100 days.

For data recording in sleep mode go to ALMEMO® Control <Device programming> and take the following steps:

1. Enter a cycle lasting at least two minutes.
2. Activate saving to memory in the cycle.
3. Switch sleep mode on.
4. Start measuring operation as normal; the device should then switch off automatically; as a check the LED 'ON' (3) should flash rhythmically on and off.
6. In the specified cycle the device switches on automatically, performs one measuring point scan, and then switches off again.
7. To stop the measuring operation press key (2) twice, Function 'ON' and 'STOP'.

In this way any number of measuring operations can be performed in sleep mode up until when sleep mode is deactivated again. With cycles shorter than two minutes measuring operations are performed automatically in normal mode.

10.2.2 Measured value memory, internal

Measured data acquisition module ALMEMO® 809 incorporates an 8-MB flash memory, sufficient for up to 1,600,000 measured values (depending on the number of channels and measured value volume). This memory is non-volatile; i.e. it retains data intact even in the event of a failure affecting the lithium battery used to buffer the real-time clock. The system for organizing the measured value memory has been changed; measured values are now saved in ASCII and in table format (similar to the system used for interface output). When a connector's configuration is modified the new configuration is now saved and, if the linear memory mode has been selected, is assigned a number (similar to the system used for the memory card). These 'files' can be individually selected and output. The ring memory mode remains an available alternative. (see Man. 6.10.13.2) However, if the ring memory mode has been selected, the connector configuration cannot be changed.

The following functions are supported by the internal memory:

- Linear memory mode - multiple connector configurations can be saved.

10. Measured data acquisition

- Ring memory mode - only one connector configurations can be saved.
- Sleep mode
- Data is output in table format only.
- Selective data output by date only
- Selective data output by number

10.2.3 Memory connector with SD memory card

Another convenient method for data recording is memory connector ZA 1904-SD with a conventional micro SD memory card. Measured data is written to the memory card via the plug-in memory connector; this data is saved in standard FAT16 table format. The memory card can be formatted and its contents can be read out and / or deleted on any normal PC using any standard card reader. (see Manual, 6.9.4.2) This data can also be imported into MS-Excel or into WinControl. The memory connector works in a completely different way to the device-internal memory; this brings with it not only restrictions but also new advantages.

Memory connector functions

- Virtually unlimited memory capacity
- With each new connector configuration a new file is created.
- Ring memory mode is not supported.
- Sleep mode
- Data can be evaluated using any reader on site or anywhere else.
- Very fast data transfer via the reader
- Data recording and output in table format only
- On the ALMEMO® device itself only the last file can be read.
- Selective data output according to date and time-of-day or by number code is not supported

The memory connector with the memory card can be connected at socket A2; it will be recognized automatically. If at the start of any measuring operation an external memory has been connected, it will be used. In the course of a measuring operation the external memory must not be unplugged; all temporarily buffered measured values would be lost.

Before starting any measuring operation you can enter an 8-character file name. (see Ch. 11) In the absence of a user-defined file name, the default 'ALMEMO.001' or the name most recently used will be suggested automatically. So long as the connector configuration is not altered, any number of measuring operations can be saved - either manually or cyclically, also with number codes, all in the same file.

If, however, the connector configuration has been changed since the last measuring operation, a new file will be created; and, if no new file name has been programmed, the index in the file name extension will automatically be incremented by 1, e.g. 'ALMEMO.002'. Similarly, if the file name now entered already exists, a new file will be created with the same file name prefix but with a new index.

11. SPECIAL MEASURED QUANTITIES, LINEARIZATION, MULTI-POINT CALIBRATION

Thanks to the new ALMEMO® V6 connectors with extra memory for additional data (bigger EEPROM, code E4) the following tasks can now be performed with a certain elegance.

1. Provision of special measuring quantities with internal characteristic
2. User-defined linearization of linear signals for voltage, current, resistance, or frequency
3. Multi-point calibration of all sensors
4. Serial number and calibration data management in the sensor

The ALMEMO® 809 can as standard evaluate all appropriately programmed special connectors. With option KL it is also possible to convert measuring signals into equivalent display values based on a characteristic of up to 35 interpolated values. These control points can be programmed and saved in the EEPROM in the ALMEMO® connector using the ALMEMO® Control software (menu <Measuring points> list <Program measuring point>, <Measuring point>, multi-point calibration / special linearization). During a measuring operation the measured values between these points are interpolated on a linear basis. When correcting non-linear sensors (e.g. with Pt100 or thermocouple sensors) initially the original characteristic is considered; and only then are the deviations interpolated on a linear basis and inserted.

If a channel with a characteristic is deactivated or programmed with a different quantity, the characteristic can subsequently be reactivated by restoring the special quantity using command 'B99'.

Other information that can be entered in the extended connector includes the order number, the serial number, the date of the next calibration, and the calibration interval. In networked systems the calibration intervals can thus be monitored automatically.

12. TROUBLE-SHOOTING

The ALMEMO® 809 measured data acquisition module can be configured and programmed in many different ways. This system is suitable for connecting a wide variety of very different sensors, additional measuring instruments, alarm signaling devices, and peripheral equipment. Given these numerous possibilities the device may in certain circumstances not behave quite as expected. The cause of such unexpected behavior is not usually a device defect; often the cause is incorrect operation by the user, an invalid setting, or unsuitable cabling. In such event try to pinpoint and clear the problem with the aid of the following tests.

Error: No or all LEDs light up; keys do not react.

Remedy Check the power supply; charge the battery; switch off and then on again; if necessary re-initialize (see 7.4)

12. Trouble-shooting

- Error** Measured values are incorrect.
- Remedy** Check all the channel programming very carefully, especially the base value and zero-point (sensor programming and special functions).
- Error** Measured values fluctuate unexpectedly or the system hangs in mid-operation.
- Remedy** Check the cabling for any inadmissible electrical connections. For sensors with their own integrated power supply check element flag 5. see 8.5
Unplug any suspicious sensors. In its place connect a hand-held sensor in air or phantom mode (for thermocouples short-circuit A-B, for Pt100 sensors use 100Ω resistor) and check.
Connect the sensors again one at a time and check successively. If a fault persists for any one connection, check all wiring; if necessary, insulate the sensor and eliminate interference by using shielded or twisted wiring.
- Error** Data transmission via the interface does not function.
- Remedy** Check the interface module, connections, and settings.
Ensure that both devices are set to the same baud rate and transmission mode.(see Manual, 6.10.12)
A reset with the interface module connected will set the baud rate to 9600 baud. (see 7.4)
Ensure that the correct COM port on the computer is being addressed.
Test data transmission by means of a terminal (ALMEMO® Control, WinControl, WINDOWS Terminal). Address the device using its assigned device number 'Gxy'. (see Man. 6.2.1) If the device is in the XOFF status, enter <ctrl Q> for XON. Check the programming by means of 'P15'. (see Man. 6.2.3) Test the transmit line only by entering the start command 'S2'; the LED START should light up.
Test the receive line only by pressing the START / STOP key.
- Error** Data transmission in the network does not function.
- Remedy** Check to ensure that all devices are assigned different addresses. Address all devices individually via the terminal using command 'Gxy'. Addressed device is OK if at least 'y CR LF' is returned as echo. If transmission is still not possible, unplug the networked devices. Check all devices individually on the data cable to the computer. (see above)
Check the wiring for short-circuit or crossed wires. Ensure that all network distributors are supplied with power. Network the devices again one after the other and check successively. (see above)

If, after performing the above-listed checks and remedial steps, a device still fails to behave as described in the operating instructions, it must be returned to

our factory in Holzkirchen, accompanied by a brief explanatory note, error description, and if available test printouts. With the ALMEMO® Control software you can print out screenshots showing the relevant programming details and save and / or print out a comprehensive 'function test' in the device list or terminal mode.

13. DECLARATION OF CONFORMITY



Doc-Nr. CE_MA809_001_20181005_R1.doc

EU-Konformitätserklärung

EU-Declaration of Conformity
nach/according to EN 17050-1

Hersteller: Ahlborn Mess- und Regelungstechnik GmbH
Manufacturer:
Adresse: Eichenfeldstrasse 1
Address: 83607 Holzkirchen
 Germany

bestätigt, dass das Produkt
declares, that the product

Produktbezeichnung: Präzisionsmessgerät Almemo® 809
Product Name:
Produkt Typ: MA809
Product Type:
Produkt Optionen: Alle/all
Product Options:

den nachfolgenden Europäischen Anforderungen und Richtlinien entspricht und folglich das CE Zeichen trägt.
conforms to following European Product Specifications and Regulations and carries the CE marking accordingly.

2014/35/EU Niederspannungsrichtlinie
Low Voltage Directive
 2014/30/EU EMV Richtlinie
EMC Directive
 2014/53/EU R&TTE Richtlinie
R&TTE Directive

Angewandte harmonisierte Normen und technische Spezifikationen:
Applied harmonised standards and technical specifications: Sicherheit (Safety)
 EN 61010-1: 2010+A1
EMV (EMC)
 EN 61326-2-3: 2013 Tabelle 2

Holzkirchen, 05.10.2018
 Ort, Datum der Ausstellung
Place, date of issue

 Entwicklungsleitung

 Qualitätsmanagement

14. ANNEX

14.1 Technical data

(see. Man. 2.3)

Measuring inputs:	9	ALMEMO®	meas.
sockets	for	ALMEMO®	standard,
Potential separation		D6, and D7 sensors with ALMEMO® flat connector	
A/D converter		Photovoltaic relays for analog sensors	
Sensor power supply		Delta-sigma, 24-bit, 2.5/10/50/100 MOPS, electr. Isol.	
Outputs		12 V, 0.4 A (with DC cable ZB 3090-UK, 0.2 A)	
Standard equipment		2 ALMEMO® sockets, suitable for all output modules	
Operation		1 key	
Date and time-of-day		Real-time clock, buffered by lithium battery	
Memory		8-MB flash memory (for up to 1,500,000 meas. values)	
Power supply		external, 9 to 13 VDC	
Mains adapter 809		ZB 1212-NAx; 230 VAC to 12 VDC, min. 1 A	
Current consumption		without input and output modules: Active mode approx. 45 mA Sleep mode approx. 0.05 mA	
Housing		Polystyrene 180 x 49 x 137 mm (LxWxH) Weight: 490g	
Operating conditions			
Operating temperature	-10 to +50 °C	Storage temperature	-20 to +60 °C
Ambient atmospheric humidity	10 to 90 % RH (non-condensing)		

14.2 Product overview

Order no.

V7 measured data acquisition module ALMEMO® 809

Nine inputs, maximum 90 channels, two outputs, cascable interface, one key, real-time clock, housed in an 8-DU case, 8-MB flash memory, mains unit 12 V, 1 A

MA 809

Options

KL: Linearization, multi-point calibration

OA 809-KL

R: Measuring ranges for temperature display for 8 refrigerants

SB 0000-R

Accessories

DC power cable, 10 to 30 VDC, 12 V / 0.25 A, electrically isolated

ZB 3090-UK

DC power cable, 10 to 30 VDC, 12 V / 1 A, electrically isolated

ZB 3090-UK2

ALMEMO® memory connector, incl. micro SD card, min. 512 MB

ZA 1904-SD

ALMEMO® data cable with USB interface, el. Isol., max.115.2 kbaud

ZA 1919-DKU

ALMEMO® data cable with V24 interface, el. Isol., max.115.2 kbaud

ZA 1909-DK5

ALMEMO® network cable, el. Isol., max.115.2 kbaud

ZA 1999-NK5

ALMEMO® data cable with Ethernet interface, el. Isol., max.115.2 kbaud

ZA 1945-DK

ALMEMO® D7 sensor adapter cable, electr. isolated, length 25 cm

ZA D700-GT

ALMEMO® D7 extension cable, not electr. isolated, length xx cm

ZA D700-VKxx

ALMEMO® recording cable, -1.25 to 2.00 V

ZA 1601-RK

ALMEMO® input / output cable for triggering and limit value alarm

ZA 1000-EGK

ALMEMO® V6 relay trigger adapter (4 relays, 2 trigger inputs)

ZA 8006-RTA3

Option of two analog outputs, electr. Isol. configurable 10 V or 20 mA

OA 8006-R02

14.3 Index

Accessories.....	30	Operating conditions	30
additional channels	19	operating controls.....	21
ALMEMO® Control.....	14	Operating controls.....	2
channel numbering	19	Options	30
code switches	21	Order no.	30
Code switches.....	2	Output sockets	2
Combination key	21	Potential separation	20
Configuration, new V7 functions	22	Power supply.....	16, 30
Connecting sensors / transducers	18	Process control	12
.....	18	Product overview.....	30
connector configuration	26	Putting into service.....	15
D6 sensors.....	18	read out the measured data	24
D7 sensors.....	19	ring memory	25
Data buffering	16	Safety instructions.....	7
DC supply socket.....	2	scan cycle.....	22
Device address	21	SD memory card	26
electrically isolated.....	20	Sensor programming.....	10
External DC voltage supply	16	Sensor supply	16
file name	26	Sleep mode	25
Functions of the ALMEMO 809..	10	smoothing.....	23
Ground socket.....	2	socket DC.....	16
Housing.....	30	Software	14
Introduction	9	Special measured quantities	27
Key.....	2	Standard delivery	6
Linearization.....	27	Standard equipment.....	30
Mains operation	16	Standard sensors (V5,V6).....	18
Measured data acquisition.....	24	start and stop a measuring	
Measured value memory, internal		operation	24
.....	25	Status LEDs	2
Measuring inputs	19, 30	switch the device OFF.....	16
Measuring operation	11	Switching ON / OFF, reinitialization	
Measuring sockets.....	2	16
measuring speed	22	Technical data	30
Memory connector	26	Trouble-shooting	27
Minimum time.....	22	Warranty.....	5
networking.....	21	Waste disposal.....	6
Offline measurement.....	24	WinControl.....	14
Online measurement with PC	24		

YOUR CONTACT

AHLBORN Mess- und Regelungstechnik GmbH
Eichenfeldstraße 1
83607 Holzkirchen
Germany

internet : <http://www.ahlborn.com>
e-mail : amr@ahlborn.com

**Despite great care, incorrect information cannot be ruled out.
Technical changes are reserved.**